

Maxi 100 System Ductile Grate / C250 / Slotted

Product Specifications

Part. No.:
865-M4DICT

Load Class:
C250 (55,100 lbs) according EN 1433
Certified by MPA-HB (independent laboratories)

Material: Ductile Iron GJS-500-7 (ASTM A536 70-50-05) **Locking:** Patented boltless grate locking system

Surface:
Longitudinal slot design (0.55" x 4.72") ensures high water intake

Weight: 12.13 lbs (5.5kg) **Water intake:** 85.87 in² (554 cm²) per meter

Use:
This grate is developed for use with HydroTec MAXI 100 channels made of fiber reinforced concrete with a ductile iron edge protection.

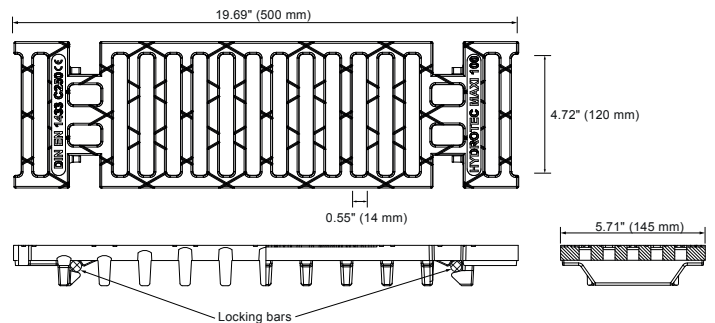
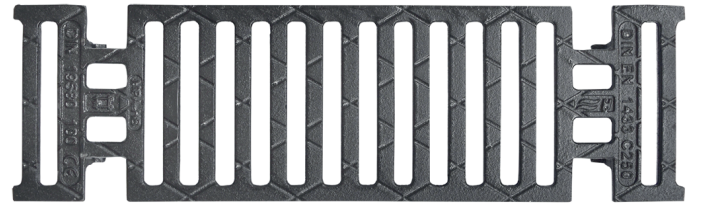

Fiber Reinforced Concrete Channel

Available heights(h):

- 3.15" (80mm)
- 4.33" (110mm)
- 6.30" (160mm)
- 7.28" (185mm)
- 8.27" (210mm)
- 9.25" (235mm)
- 10.24" (260mm)
- Sloped* (30 sections)

* Elements have a 0.50% internal slope

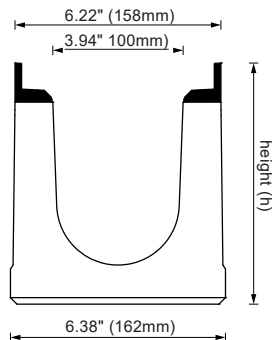

System Specifications

Grate Locking Tool (Part No. 865-TOOL) :
The Grate Locking Tool is made of galvanized steel. It's used to lock and unlock the grate.

Grate:
The grate is made of ductile iron and certified to EN 1433 Load Class C250.

Locking Bar (Part No. 865-4LR):
Two locking bars fix the grate to the channel body. They're unlocked by the Grate Locking Tool .

MAXI 100 Channel:
The channel body is made of fiber reinforced concrete with a ductile iron edge protection. Connecting profiles at the end of the channel guarantee an easy and fast installation.

