

ITEM	PART NO.	DESCRIPTION	QTY.
1	DG0641D	GRATE: DUCTILE IRON SLOTTED 2FT	6
2	DA0542BH	LOCKING DEVICE	6
3	DP0500C	END CAP – SOLID	2
4	DA0633	INSTALLATION CHAIR	4
5	DA0700PE	FRAME 700 SERIES HDPE 2FT	6
6	DP0500	CHANNEL NEUTRAL POLYCAST 500 – 48.00"	3
7	LIT-PC8	INSTALLATION MANUAL	1

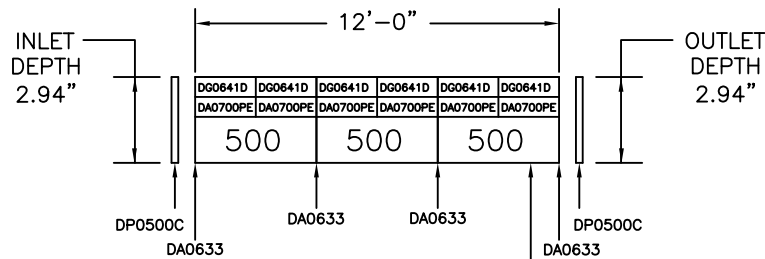

BOTTOM OUTLET  
(BY CUSTOMER)

DRILL SIZE 3.50" FOR 3.0" SCH 40 & 80 PVC  
 DRILL SIZE 4.25" FOR 4.0" SCR-35 SEWER & DRAIN  
 DRILL SIZE 4.50" FOR 4.0" SCH 40 & 80 PVC

CUSTOMER APPROVAL

DATE: \_\_\_\_\_

NAME: \_\_\_\_\_

SIGNATURE: \_\_\_\_\_

I HAVE REVIEWED THE SYSTEM DIMENSIONS PROVIDED AND APPROVE TDS TO PROCEED WITH RELEASING FOR PRODUCTION. I UNDERSTAND THAT ONCE RELEASED FOR PRODUCTION, ANY REVISION WILL RESULT IN ADDITIONAL CHARGES.

CUSTOM ITEMS ARE NON-RETURNABLE

### STANDARD CHAIR INSTALLATION

(SECURE CHAIR IN BOTTOM DIMPLES ON THE CHANNELS)

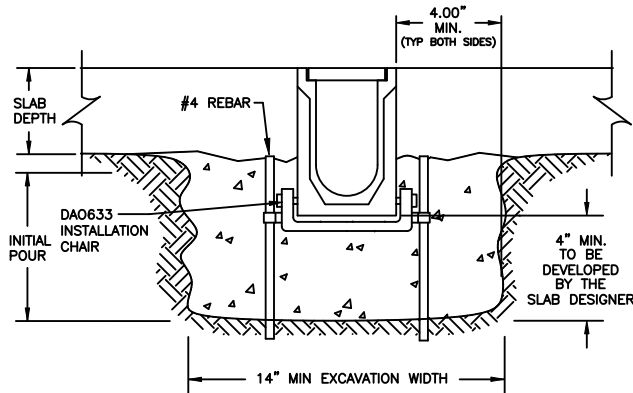

### CHANNEL OUTLET DETAILS

(ALL END CAPS ARE TO BE SECURED WITH AN ADHESIVE)

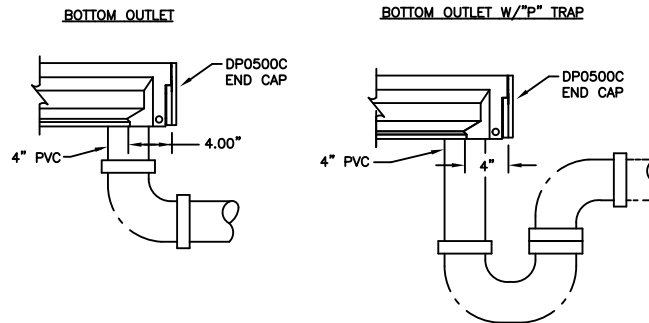

DISCLAIMER – THE CUSTOMER AND THE CUSTOMER'S ARCHITECTS, ENGINEERS, CONSULTANTS, AND OTHER PROFESSIONALS ARE COMPLETELY RESPONSIBLE FOR THE SELECTION INSTALLATION AND MAINTENANCE OF ANY PRODUCT PURCHASED FROM TRENCH DRAIN SYSTEMS AND/OR ITS MANUFACTURERS. TRENCH DRAIN SYSTEMS MAKES NO WARRANTY, EXPRESS OR IMPLIED, AS TO THE SUITABILITY, DESIGN, MERCHANTABILITY, OR FITNESS OF THE PRODUCT FOR CUSTOMERS APPLICATION. THE DRAWING AND INFORMATION PROVIDED REMAIN THE PROPERTY AND COPYRIGHT OF THE MANUFACTURER LISTED. THE MANUFACTURER RESERVES THE RIGHT TO MODIFY SPECIFICATION WITHOUT NOTICE.

REV	DESCRIPTION	BY	DATE



TRENCH DRAIN SYSTEMS  
 PO BOX 377  
 FREMONT, OH 43420  
 610-638-1221

DRAWN: CJP  
 CHECKED: \_\_\_\_\_  
 DATE: 6.13.19

DESCRIPTION  
 POLYCAST 500  
 SYSTEM LENGTH; 12FT  
 PE FRAME – DG0641D GRATE

DWG. NO.  
 PCK5-DG0641D-PF-12

DO NOT SCALE DRAWING    WEIGHT: 239#    SHEET 1 OF 1

PROPRIETARY AND CONFIDENTIAL; THE INFORMATION CONTAINED IN THIS DRAWING IS THE SOLE PROPERTY OF TDS. ANY REPRODUCTION IN PART OR WHOLE WITHOUT THE WRITTEN PERMISSION OF TDS IS PROHIBITED.