

ITEM	PART NO.	DESCRIPTION	QTY.
1	DG0641D	GRATE: DUCTILE IRON SLOTTED 2FT	6
2	DA0542B	LOCKING DEVICE	6
3	DP0500C	END CAP – SOLID	2
4	DA0633	INSTALLATION CHAIR	4
5	DA0620A	CHANNEL EDGE PROTECTOR GALV – 48.00"	3PR
6	DP0500	CHANNEL NEUTRAL POLYCAST 500 – 48.00"	3
7	LIT-PC8	INSTALLATION MANUAL	1

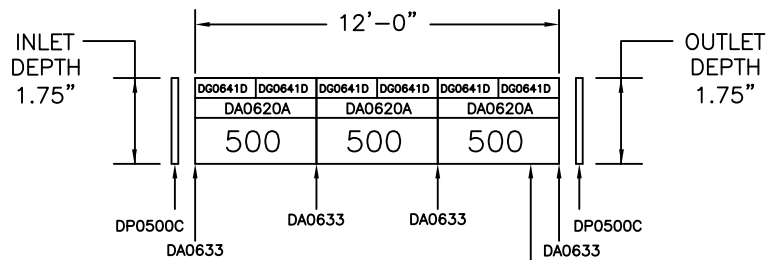

BOTTOM OUTLET
(BY CUSTOMER)

DRILL SIZE 3.50" FOR 3.0" SCH 40 & 80 PVC
 DRILL SIZE 4.25" FOR 4.0" SCR-35 SEWER & DRAIN
 DRILL SIZE 4.50" FOR 4.0" SCH 40 & 80 PVC

CUSTOMER APPROVAL

DATE: _____

NAME: _____

SIGNATURE: _____

I HAVE REVIEWED THE SYSTEM DIMENSIONS PROVIDED AND APPROVE TDS TO PROCEED WITH RELEASING FOR PRODUCTION. I UNDERSTAND THAT ONCE RELEASED FOR PRODUCTION, ANY REVISION WILL RESULT IN ADDITIONAL CHARGES.

CUSTOM ITEMS ARE NON-RETURNABLE

DISCLAIMER – THE CUSTOMER AND THE CUSTOMER'S ARCHITECTS, ENGINEERS, CONSULTANTS, AND OTHER PROFESSIONALS ARE COMPLETELY RESPONSIBLE FOR THE SELECTION INSTALLATION AND MAINTENANCE OF ANY PRODUCT PURCHASED FROM TRENCH DRAIN SYSTEMS AND/OR ITS MANUFACTURERS. TRENCH DRAIN SYSTEMS MAKES NO WARRANTY, EXPRESS OR IMPLIED, AS TO THE SUITABILITY, DESIGN, MERCHANTABILITY, OR FITNESS OF THE PRODUCT FOR CUSTOMERS APPLICATION. THE DRAWING AND INFORMATION PROVIDED REMAIN THE PROPERTY AND COPYRIGHT OF THE MANUFACTURER LISTED. THE MANUFACTURER RESERVES THE RIGHT TO MODIFY SPECIFICATION WITHOUT NOTICE.

STANDARD CHAIR INSTALLATION

(SECURE CHAIR IN BOTTOM DIMPLES ON THE CHANNELS)

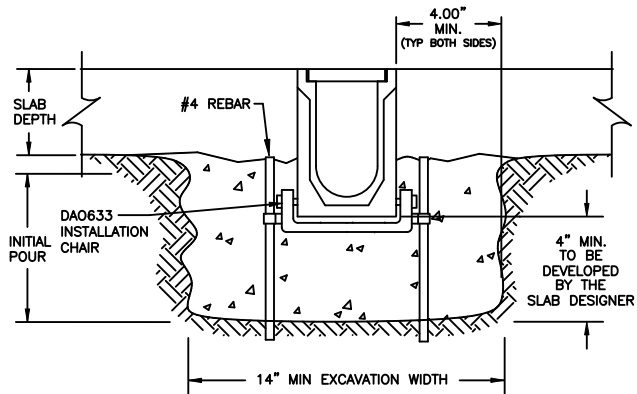

CHANNEL OUTLET DETAILS

(ALL END CAPS ARE TO BE SECURED WITH AN ADHESIVE)

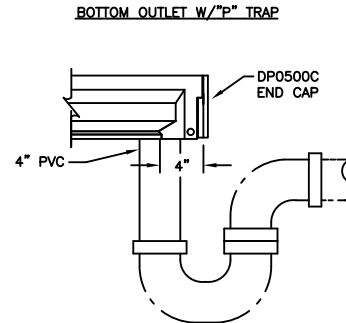
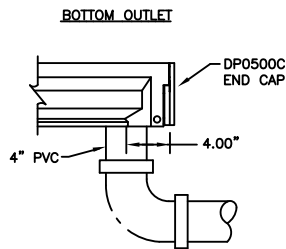

REV	DESCRIPTION	BY	DATE
	DRAWN: CJP		DATE: 6.13.19
	CHECKED:		
<p align="center">TDS</p> <p align="center">TRENCH DRAIN SYSTEMS</p> <p align="center">PO BOX 377 FREMONT, OH 43420 610-638-1221</p>			
DESCRIPTION		POLYCAST 500 SYSTEM LENGTH; 12FT GV EDGING – DG0641D GRATE	
DWG. NO.		PCK5-DG0641D-GE-12	
DO NOT SCALE DRAWING	WEIGHT: 295#	SHEET 1 OF 1	

PROPRIETARY AND CONFIDENTIAL; THE INFORMATION CONTAINED IN THIS DRAWING IS THE SOLE PROPERTY OF TDS. ANY REPRODUCTION IN PART OR WHOLE WITHOUT THE WRITTEN PERMISSION OF TDS IS PROHIBITED.