

| ITEM | PART NO. | DESCRIPTION                              | QTY. |
|------|----------|--|------|
| 1    | DG0640R  | GRATE: GALVANIZED SLOTTED REINFORCED 4FT | 9    |
| 2    | DA0542BH | LOCKING DEVICE                           | 18   |
| 3    | DP0500C  | END CAP – SOLID                          | 2    |
| 4    | DA0633   | INSTALLATION CHAIR                       | 10   |
| 5    | DA0700PE | FRAME 700 SERIES HDPE 2FT                | 18   |
| 6    | DP0500   | CHANNEL NEUTRAL POLYCAST 500 – 48.00"    | 9    |
| 7    | LIT-PC8  | INSTALLATION MANUAL                      | 1    |

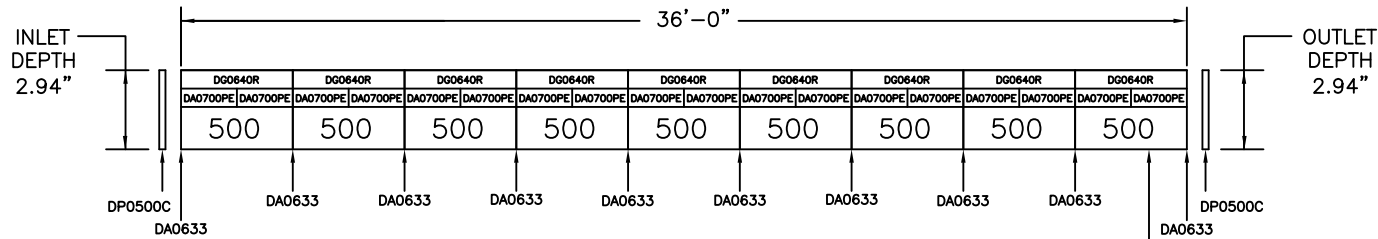

BOTTOM OUTLET  
(BY CUSTOMER)

DRILL SIZE 3.50" FOR 3.0" SCH 40 & 80 PVC  
 DRILL SIZE 4.25" FOR 4.0" SCR-35 SEWER & DRAIN  
 DRILL SIZE 4.50" FOR 4.0" SCH 40 & 80 PVC

CUSTOMER APPROVAL

DATE: \_\_\_\_\_

NAME: \_\_\_\_\_

SIGNATURE: \_\_\_\_\_

I HAVE REVIEWED THE SYSTEM DIMENSIONS PROVIDED AND APPROVE TDS TO PROCEED WITH RELEASING FOR PRODUCTION. I UNDERSTAND THAT ONCE RELEASED FOR PRODUCTION, ANY REVISION WILL RESULT IN ADDITIONAL CHARGES.

CUSTOM ITEMS ARE NON-RETURNABLE

DISCLAIMER – THE CUSTOMER AND THE CUSTOMER'S ARCHITECTS, ENGINEERS, CONSULTANTS, AND OTHER PROFESSIONALS ARE COMPLETELY RESPONSIBLE FOR THE SELECTION INSTALLATION AND MAINTENANCE OF ANY PRODUCT PURCHASED FROM TRENCH DRAIN SYSTEMS AND/OR ITS MANUFACTURERS. TRENCH DRAIN SYSTEMS MAKES NO WARRANTY, EXPRESS OR IMPLIED, AS TO THE SUITABILITY, DESIGN, MERCHANTABILITY, OR FITNESS OF THE PRODUCT FOR CUSTOMERS APPLICATION. THE DRAWING AND INFORMATION PROVIDED REMAIN THE PROPERTY AND COPYRIGHT OF THE MANUFACTURER LISTED. THE MANUFACTURER RESERVES THE RIGHT TO MODIFY SPECIFICATION WITHOUT NOTICE.

### STANDARD CHAIR INSTALLATION

(SECURE CHAIR IN BOTTOM DIMPLES ON THE CHANNELS)

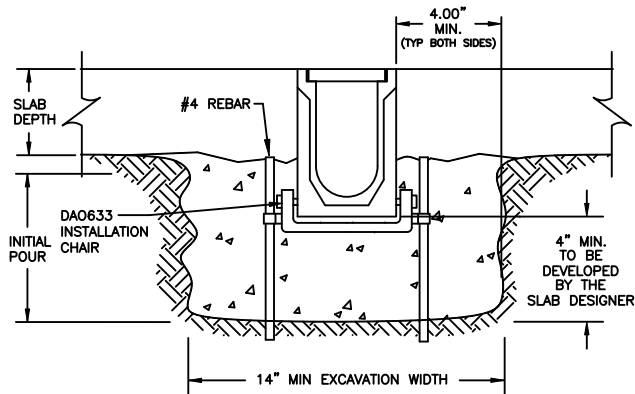

### CHANNEL OUTLET DETAILS

(ALL END CAPS ARE TO BE SECURED WITH AN ADHESIVE)

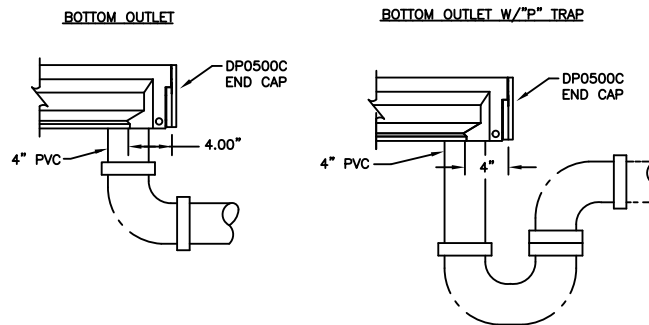

| REV | DESCRIPTION | BY | DATE |
|-----|-------------|----|------|
|     |             |    |      |

|  |  |               |
|--|--|---------------|
| <br>TRENCH DRAIN SYSTEMS<br>PO BOX 377<br>FREMONT, OH 43420<br>610-638-1221 | DRAWN: CJP<br>CHECKED: _____<br>DESCRIPTION<br>POLYCAST 500<br>SYSTEM LENGTH; 36FT<br>PE FRAME – DG0640R GRATE<br>DWG. NO.<br>PCK5-DG0640R-PF-36<br>DO NOT SCALE DRAWING    WEIGHT: 456#    SHEET 1 OF 1 | DATE: 6.13.19 |
|--|--|---------------|

PROPRIETARY AND CONFIDENTIAL; THE INFORMATION CONTAINED IN THIS DRAWING IS THE SOLE PROPERTY OF TDS. ANY REPRODUCTION IN PART OR WHOLE WITHOUT THE WRITTEN PERMISSION OF TDS IS PROHIBITED.