

FG-I4015

GRATE FIBERGLASS I4015

PART NO.	DIM A
FG-I4015-0948	9.00 [229]
FG-I4015-1248	12.00 [305]
FG-I4015-1548	15.00 [381]



DIN APPLICATION LOAD CLASS C:
 CURB SIDES, HIGHWAY SHOULDERS
 AND PARKING AREAS. DESIGNED
 FOR A DISTRIBUTED PRESSURE OF 56,
 200 LBS. (250kN)

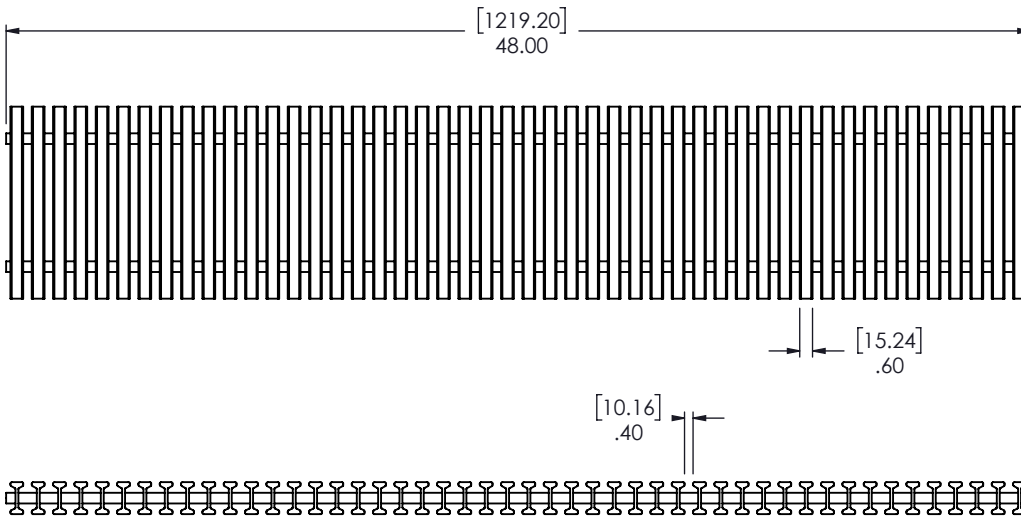
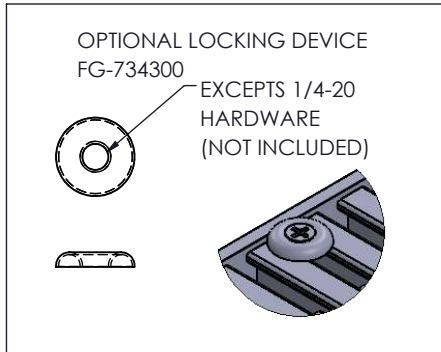
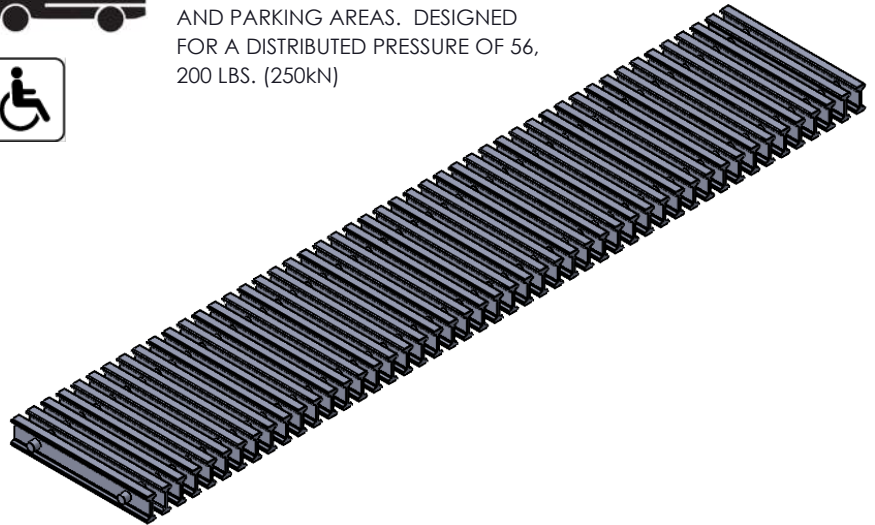

MANUFACTURER



DISCLAIMER - The customer and the customer's architects, engineers, consultants, and other professionals are completely responsible for the selection installation and maintenance of any product purchased from Trench Drain Systems and/or its manufacturers. TRENCH DRAIN SYSTEMS MAKES NO WARRANTY, EXPRESS OR IMPLIED, AS TO THE SUITABILITY, DESIGN, MERCHANTABILITY, OR FITNESS OF THE PRODUCT FOR CUSTOMERS APPLICATION. The drawing and information provided remain the property and copyright of the manufacturer listed. The manufacturer reserves the right to modify specification without notice.

ENGINEERING SPECIFICATION

TDS FIBERGLASS GRATES ARE NONCONDUCTIVE, LIGHTWEIGHT SAFE-T-SPAN GRATING MANUFACTURED FROM A FIRE-RETARDANT ISOPHTHALIC POLYESTER RESIN (ISOFR). CORROSION- AND SLIP-RESISTANT MATERIAL REPLACES STEEL BAR GRATING. THE HIGH PERCENTAGE OF GLASS PROVIDES DURABILITY AND HIGH UNIDIRECTIONAL STRENGTH AND STIFFNESS MAKING THIS THE IDEAL PRODUCT FOR APPLICATIONS WHERE LONGER SUPPORT SPANS ARE REQUIRED. SUPPORT LOADS IN THE SPAN DIRECTION ONLY. THE GRATE HAS AN OPEN AREA OF 40% AND IS ADA APPROVED. EACH GRATE MEASURES 1.50" THICK X 48.00" LONG.