

DG0675HD

POLYCAST 600 SERIES DUCTILE IRON LONGITUDINAL SLOTTED GRATE



PART NO.	MATERIAL	WEIGHT	OPEN AREA	FLOW RATE
DG0675HD	DUCTILE IRON	15 LBS.	26%	54.50 GPM PER LINEAR FOOT WITH 1/2" OF HEAD

**DIN APPLICATION LOAD CLASS D:** HIGHWAY VEHICLE, COMMERCIAL AIRCRAFT AND LOW TO MODERATE SPEEDS (PARKING AREA, DRIVEWAYS AND WAREHOUSES).  
 DESIGNED FOR A DISTRIBUTED PRESSURE OF 89,9820 LBS. (400kN)

**MEETS THE FOLLOWING STANDARDS & SPECIFICATIONS:**

- FEDERAL AVIATION ADMINISTRATION (FAA) ADVISORY CIRCULAR AIRPORT PAVEMENT DESIGN AND EVALUATION (AC 150/5320-6D APPENDIX 3 DESIGN OF STRUCTURES FOR HEAVY AIRCRAFT)
- AASHTO HIGHWAY DRAINAGE GUIDELINES
- AASHTO STANDARD SPECIFICATION FOR HIGHWAY BRIDGES

SYSTEM MFG	SYSTEM	LOCKING DEVICE	LOAD CLASS
HUBBELL	POLYCAST 500 w/DG0700AA FRAME	DA0542BH	F
	POLYCAST 500 w/DG0700PE FRAME	DA0542BH	E
	POLYCAST 600	DA0642B	D
	POLYCAST 700 W/ DG0700AA FRAME	DA0642BH	F
	POLYCAST 700 W/ DG0700PE FRAME	DA0642BH	E
TDS	SS0600	SS0642B	D

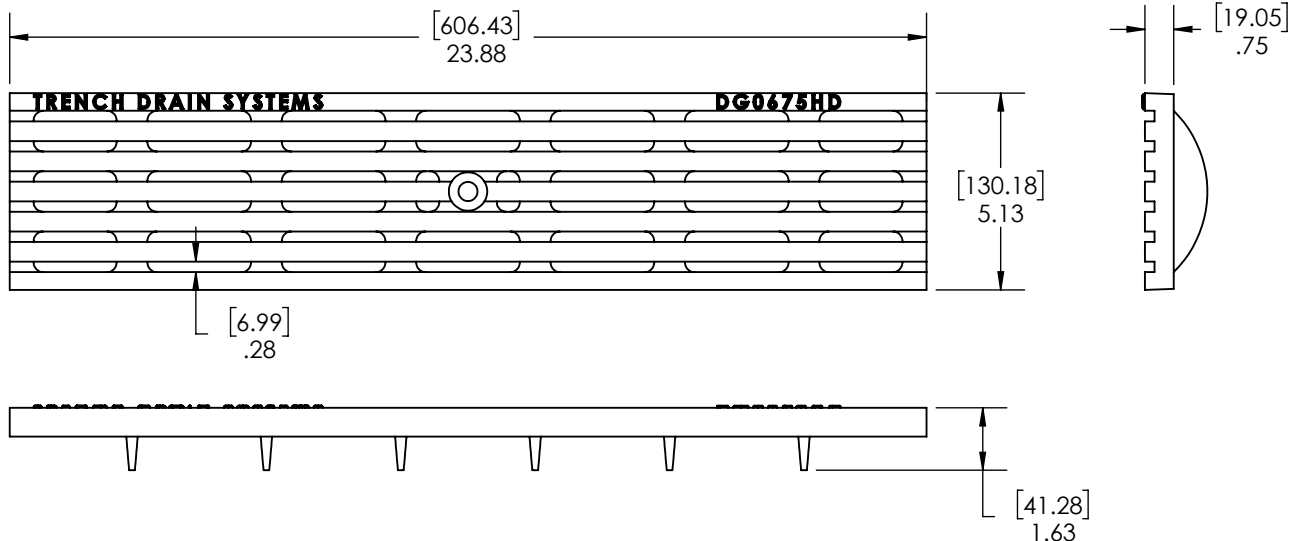

DISCLAIMER - The customer and the customer's architects, engineers, consultants, and other professionals are completely responsible for the selection installation and maintenance of any product purchased from Trench Drain Systems and/or its manufacturers. TRENCH DRAIN SYSTEMS MAKES NO WARRANTY, EXPRESS OR IMPLIED, AS TO THE SUITABILITY, DESIGN, MERCHANTABILITY, OR FITNESS OF THE PRODUCT FOR CUSTOMERS APPLICATION. The drawing and information provided remain the property and copyright of the manufacturer listed. The manufacturer reserves the right to modify specification without notice.