

DG0641D

POLYCAST 600 SERIES DUCTILE IRON SLOTTED GRATE

DIN APPLICATION LOAD CLASS D: HIGHWAY VEHICLE, COMMERCIAL AIRCRAFT AND LOW TO MODERATE SPEEDS (PARKING AREA, DRIVEWAYS AND WAREHOUSES).
 DESIGNED FOR A DISTRIBUTED PRESSURE OF 89,9820 LBS. (400kN)

- MEETS THE FOLLOWING STANDARDS & SPECIFICATIONS:
- FEDERAL AVIATION ADMINISTRATION (FAA) ADVISORY CIRCULAR AIRPORT PAVEMENT DESIGN AND EVALUATION (AC 150/5320-6D APPENDIX 3 DESIGN OF STRUCTURES FOR HEAVY AIRCRAFT)
 - AASHTO HIGHWAY DRAINAGE GUIDELINES
 - AASHTO STANDARD SPECIFICATION FOR HIGHWAY BRIDGES

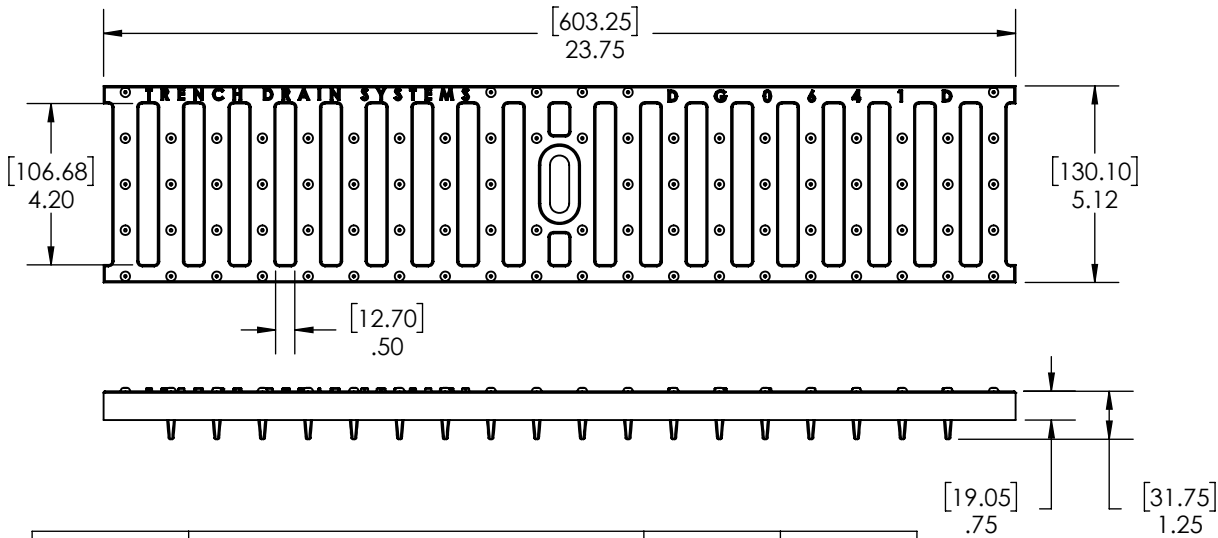
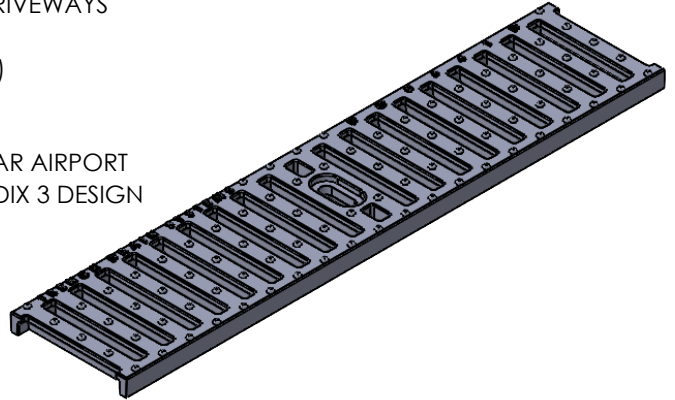

SYSTEM MFG	SYSTEM	LOCKING DEVICE	LOAD CLASS
HUBBELL	POLYCAST 500 w/DG0700AA FRAME	DA0542H	F
	POLYCAST 500 w/DG0700PE FRAME	DA0542H	E
	POLYCAST 600	DA0642	D
	POLYCAST 700 W/ DG0700AA FRAME	DA0642H	F
	POLYCAST 700 W/ DG0700PE FRAME	DA0642H	E

MANUFACTURER



DISCLAIMER - The customer and the customer's architects, engineers, consultants, and other professionals are completely responsible for the selection installation and maintenance of any product purchased from Trench Drain Systems and/or its manufacturers. TRENCH DRAIN SYSTEMS MAKES NO WARRANTY, EXPRESS OR IMPLIED, AS TO THE SUITABILITY, DESIGN, MERCHANTABILITY, OR FITNESS OF THE PRODUCT FOR CUSTOMERS APPLICATION. The drawing and information provided remain the property and copyright of the manufacturer listed. The manufacturer reserves the right to modify specification without notice.

ENGINEERING SPECIFICATION

POLYCAST DG0641D IS APPROPRIATE FOR MANY GENERAL USE CONDITIONS. GRATING LOCKING DEVICES SHOULD BE USED TO MAINTAIN THE LOAD CLASS RATING. THE GRATE HAS 39% (40IN2) OF OPEN AREA. THE GRATE IS MADE OF ASTM A536 GR 65-45-12 (DUCTILE IRON) AND WEIGHS APPROXIMATELY 8 LBS. THE GRATE IS ONLY AVAILABLE IN A 24" [610mm] LENGTH. THE GRATE MEETS LOAD CLASS D WHEN USED ALONE IN A 600 SERIES CHANNEL. IF THE GRATE IS USED IN CONJUNCTION WITH A DG0700AA FRAME IT THEN MEETS LOAD CLASS F AND A DG0700PE FRAME IT MEETS LOAD CLASS E.