



610-638-1221  
 sales@trenchdrain.com  
 PO BOX 377 - FREMONT, OH 43420

PROJECT ID: \_\_\_\_\_  
 CONTRACT NO: \_\_\_\_\_

LOCATION: \_\_\_\_\_

RELEASED: 11.23.20  
 REVISION: B

LD100X-5	LOCKING DEVICE FOR ULMA U100, D100 & HYDROPLUS w/FIBERGLASS BAR GRATE		
----------	---	--	--

GRATE TYPE	PART NO.		DIN LOAD CLASS
	0.5M	1M	
FIBERGLASS BAR 0.88" SPACING	487	486	B
FIBERGLASS BAR 0.60" SPACING	489	488	C

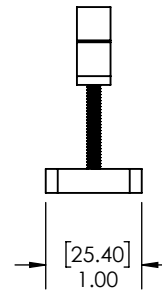
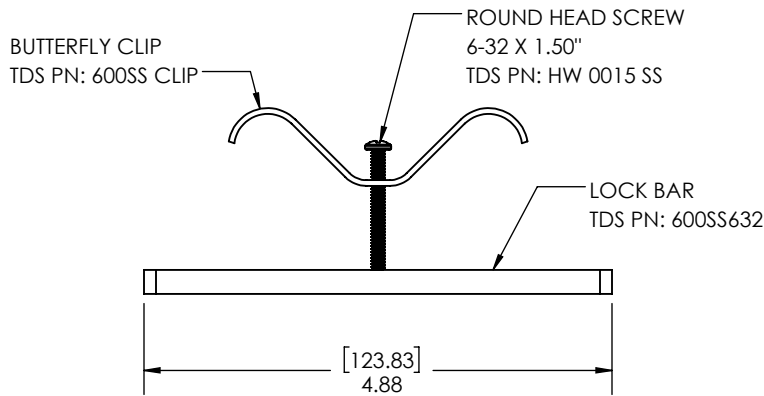
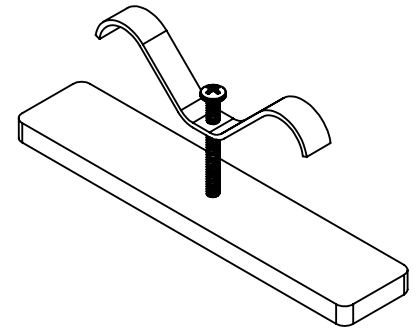

**MANUFACTURER**



DISCLAIMER - The customer and the customer's architects, engineers, consultants, and other professionals are completely responsible for the selection installation and maintenance of any product purchased from Trench Drain Systems and/or its manufacturers. TRENCH DRAIN SYSTEMS MAKES NO WARRANTY, EXPRESS OR IMPLIED, AS TO THE SUITABILITY, DESIGN, MERCHANTABILITY, OR FITNESS OF THE PRODUCT FOR CUSTOMERS APPLICATION. The drawing and information provided remain the property and copyright of the manufacturer listed. The manufacturer reserves the right to modify specification without notice.

**ENGINEERING SPECIFICATION**

TDS LD100X-5 SERIES LOCKING DEVICES ARE TO BE USED WITH ALL GRATING SYSTEMS WHERE WHEEL TRAFFIC OCCURS. THIS IS NECESSARY TO PROVIDE SYSTEM INTEGRITY. USED ON ULMA U100, D100 AND HYDROPLUS SYSTEMS.