

RELEASED 5.13.20

|        |  |
|--------|--|
| DG0645 | POLYCAST 600 SERIES GALVANIZED STEEL COVER |
|--------|--|

**APPLICATION LOAD CLASS A:** PEDESTRAIN, BICYCLES AND GOLF CARTS. DESIGNED FOR A DISTRIBUTED PRESSURE OF 2psi (300psf). ADA COMPLIANT FOR ACCESSIBLE ROUTES. MEETS ASTM C-857

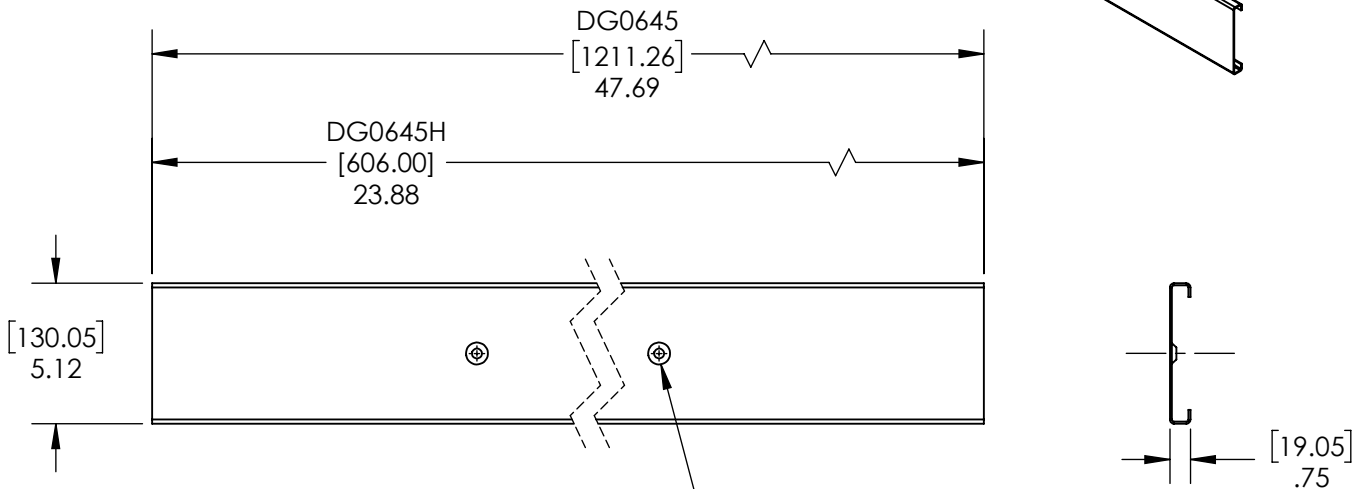
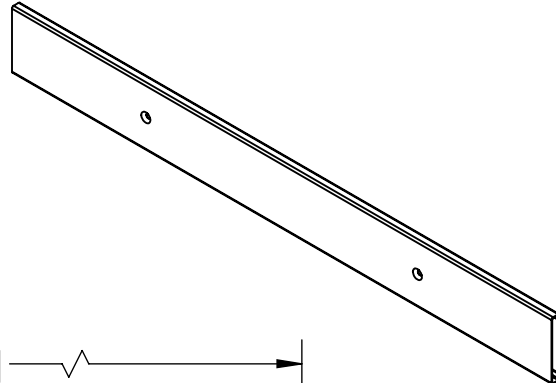

COUNTER-SUNK THRU HOLE FOR 3/8" HARDWARE. (QTY. 2) ON 48" AND (QTY. 1) 24"

**MANUFACTURER**



**SPECIFICATION**

POL YCAST® DG0645 COVER IS DESIGNED FOR PIPE RUNS, E.G. SECONDARY CONTAINMENT OR CABLE RUNS. REMOVABLE COVER ALLOWS FULL ACCESS. GRATING LOCKING DEVICE PART NO. DA0642 (NOT SHOWN) SHOULD BE USED AND MAINTAINED SECURE. THE GRATE WEIGHTS APPROXIMATELY 8lbs [3.6kg] AND IS AVAILABLE IN BOTH 24" [610mm] AND 48" [1219mm] LENGTHS.

DISCLAIMER - The customer and the customer's architects, engineers, consultants, and other professionals are completely responsible for the selection installation and maintenance of any product purchased from Trench Drain Systems and/or its manufacturers. TRENCH DRAIN SYSTEMS MAKES NO WARRANTY, EXPRESS OR IMPLIED, AS TO THE SUITABILITY, DESIGN, MERCHANTABILITY, OR FITNESS OF THE PRODUCT FOR CUSTOMERS APPLICATION. The drawing and information provided remain the property and copyright of the manufacturer listed. The manufacturer reserves the right to modify specification without notice.