

top
scale 1:4

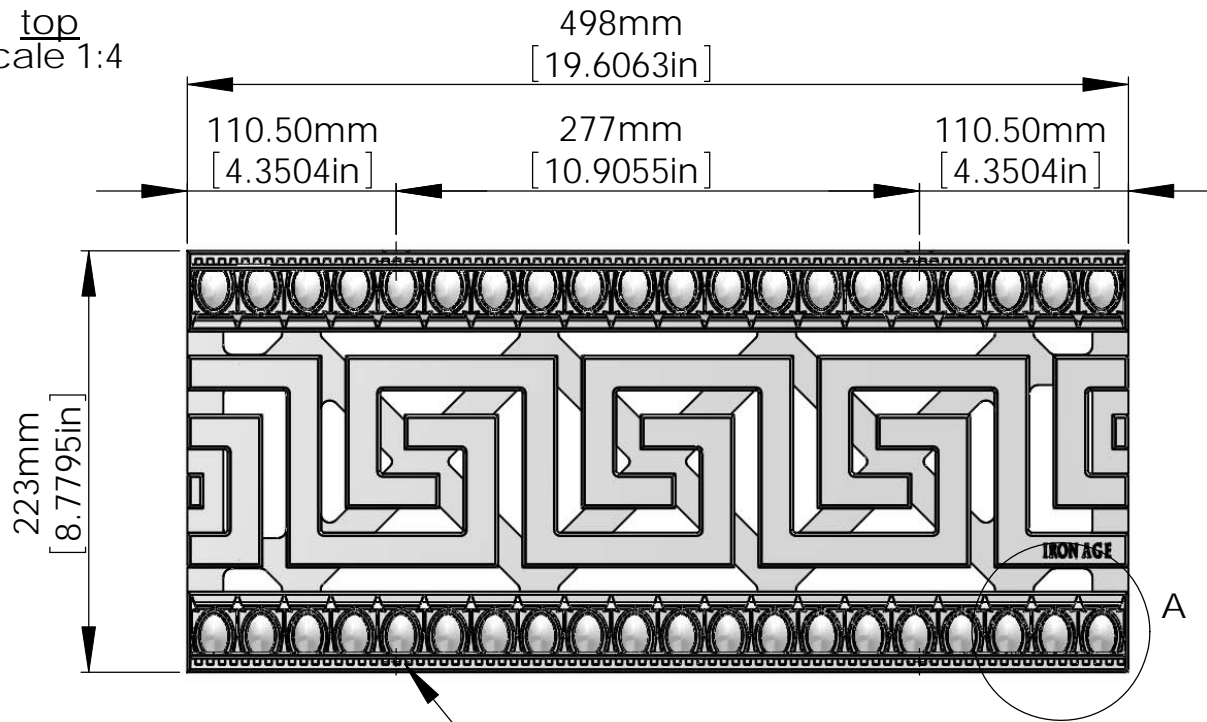

(4X) location of hole for m8 button-head screw, locations correspond w/ bolt-dn holes in MEADRAIN™ channel

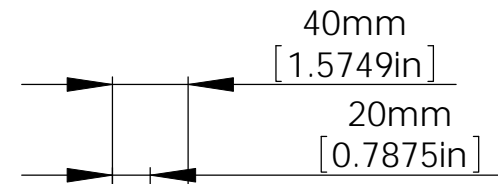

end
scale 1:4

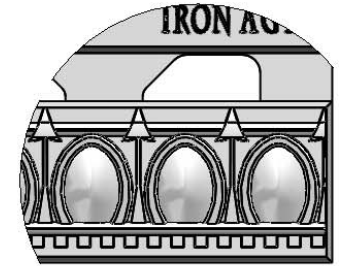

DETAIL A
SCALE 1:2

edge
scale 1:4



(4X) drill point to locate hole for PROFIX™

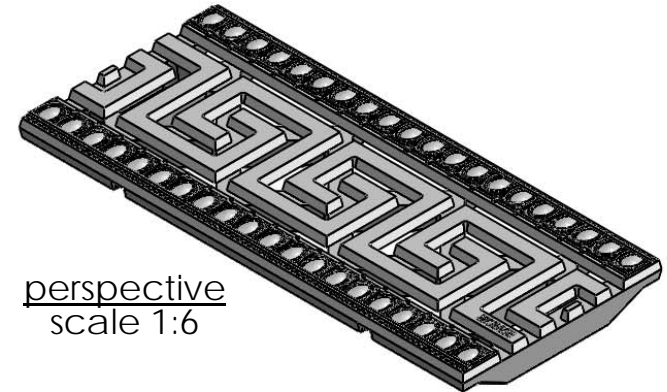

NOTES:

1. Material: cast ductile iron
2. Finish: Natural
3. Edge Thickness: 20mm
4. Replaces drain manufactured by: MEADRAIN™ D400/E600 trench drains
5. No openings greater than: 12mm
6. Due to casting inconsistencies all dimensions are nominal

patent pending © 2009 Iron Age Designs

 **IRON AGE** 2104 SW 152nd st #4 TEL 206.276.0925
DESIGNS Burién, WA 98166 FAX 206.257.0318
www.ironagedesigns.com

Greek Key 9" trench drain

Drawn by: CD

Date: 06/24/09

DWG. NO. GRK.M.E600

Scale: NTS