



DG0442

400 Series

Galvanized Steel Slotted

PROJECT ID/
CONTRACT NO: _____

LOCATION: _____

ENGINEERING SPECIFICATION:

POLYCAST® DG0442 Grate is designed for pipe runs, e.g. secondary containment or cable runs. Removable cover allows full access. Grating locking device Part No. DA0642 (not shown) should be used and maintained secure. The grate weighs approximately 8lbs [3.6kg] and is available in 48" [1219mm] lengths.

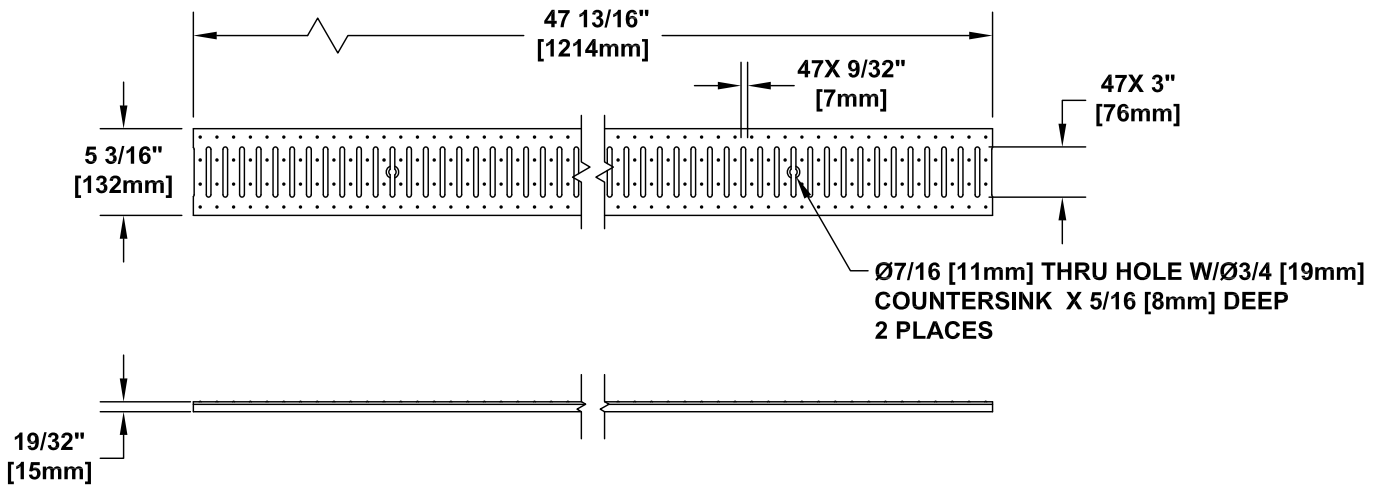
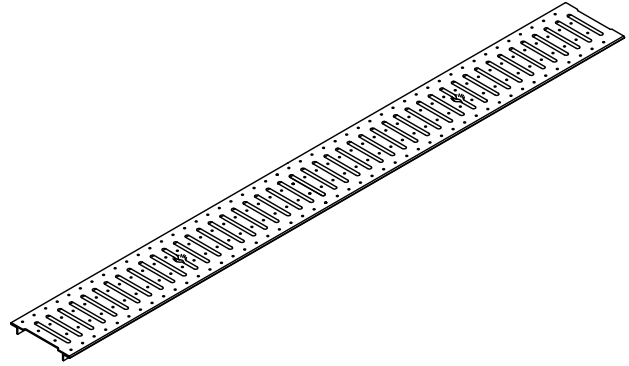

DIN APPLICATION LOAD CLASS A:

Residential, pedestrian, cyclist traffic

Designed for a distributed pressure of 3,372 lbs (15 kN).

Meets the following Standards & Specifications:

- DIN 19580 / DIN EN 1433 Drainage Channels for Vehicular and Pedestrian Areas
- The Americans with Disabilities Act of 1990: 4.5.4
- ASME A112.6.3: Section 7.12 Heel Resistant Strainers and Grates
- Australian Standard AS 3996-2006 Clause 3.3.6



www.polycastdrain.com
Toll Free Number:
1-800-346-3062