



610-638-1221
 sales@trenchdrain.com
 PO BOX 377 - FREMONT, OH 43420

PROJECT ID: _____
 CONTRACT NO: _____

LOCATION: _____

RELEASED: 2.29.24
 REVISION: -

DG0941D

POLYCAST 900 SERIES DUCTILE IRON SLOTTED GRATE



PART NO.	MATERIAL	WEIGHT	OPEN AREA	FLOW RATE
DG0941D	DUCTILE IRON	11 LBS.	56%	118.39 GPM PER LINEAR FOOT WITH 1/2" OF HEAD

DIN APPLICATION LOAD CLASS D:

HIGHWAY VEHICLE AND COMMERCIAL AIRCRAFT, LOW TO MODERATE SPEEDS. PARKING AREA, DRIVEWAYS AND WAREHOUSES. DESIGNED FOR A DISTRIBUTED PRESSURE OF 89,982 LBS. (400kN)

MEETS THE FOLLOWING STANDARDS & SPECIFICATION:

- FEDERAL AVIATION ADMINISTRATION (FFA) ADVISORY CIRCULAR AC 150/5320-6E APPENDIX 3. DESIGN OF STRUCTURES FOR HEAVY AIRPLANES.
- AASHTO H-20 AND H-25 PER AASHTO M-306 DRAINAGE, SEWER, UTILITY AND RELATED CASTINGS.

SYSTEM MFG	SYSTEM
TDS	POLYCAST 900

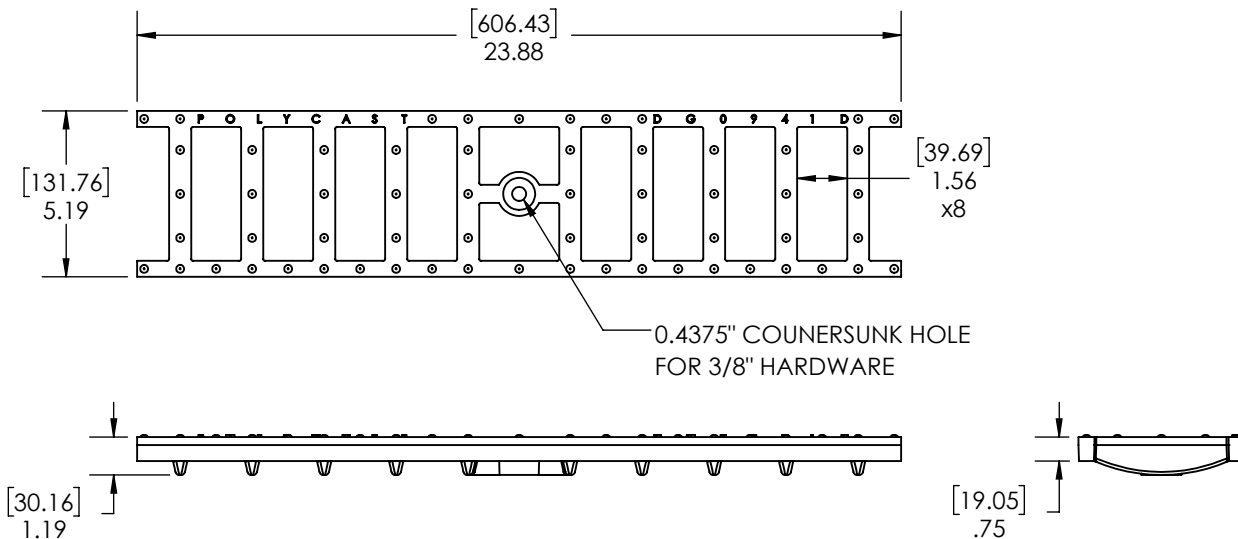

MANUFACTURER



DISCLAIMER - The customer and the customer's architects, engineers, consultants, and other professionals are completely responsible for the selection installation and maintenance of any product purchased from Trench Drain Systems and/or its manufacturers. TRENCH DRAIN SYSTEMS MAKES NO WARRANTY, EXPRESS OR IMPLIED, AS TO THE SUITABILITY, DESIGN, MERCHANTABILITY, OR FITNESS OF THE PRODUCT FOR CUSTOMERS APPLICATION. The drawing and information provided remain the property and copyright of the manufacturer listed. The manufacturer reserves the right to modify specification without notice.

ENGINEERING SPECIFICATION

TDS-POLYCAST HEAVY DUTY DUCTILE IRON GRATE DESIGNED TO SUPPORT DYNAMIC WHEEL LOADS IN EXCESS OF AASHTO H-20. THE GRATE IS DESIGNED TO BE USED IN CONJUNCTION WITH THE DG0970 FRAME AS A REMOVABLE GRATING CLEAN OUT IN LINE WITH OTHER 900 SERIES NON-REMOVABLE GRATING FOR HIGHWAY TRAFFIC CONDITIONS. GRATING LOCKING DEVICE PART NO. DA0942 (NOT SHOWN) SHOULD BE USED AND MAINTAINED SECURE. THE GRATE IS MADE OF ASTM A536 GR. 65-45-12 (DUCTILE IRON) AND WEIGHS APPROXIMATELY 11LBS (4.98KG). THE GRATE IS ONLY AVAILABLE IN A 24" [610MM] LENGTH.