

DG0900

POLYCAST 900 SERIES NON-REMOVABLE TRAFFIC GRATE



PART NO.	MATERIAL	WEIGHT	OPEN AREA	FLOW RATE
DG0900	DUCTILE IRON	15 LBS.	60%	139.67 GPM PER LINEAR FOOT WITH 1/2" OF HEAD

**DIN APPLICATION LOAD CLASS F:**

SPECIAL AREAS WITH HEAVY WHEEL LOADS, EG. AIRPORTS AND DOCKS.  
 DESIGNED FOR A DISRIBUTED PRESSURE OF 202,320 LBS. (900Kn)

**MEETS THE FOLLOWING STANDARDS & SPECIFICATION:**

- FEDERAL AVIATION ADMINISTRATION ADVISORY CIRCULAR AIRPORT PAVEMENT DESIGN AND EVALUATION (AC 150/5320-6D APPENDIX 3 DESIGN OF STRUCTURES FOR HEAVY AIRCRAFT)
- AASHTO HIGHWAY DRAINAGE GUIDELINES
- AASHTO STANDARD SPECIFICATION FOR HIGHWAY BRIDGES

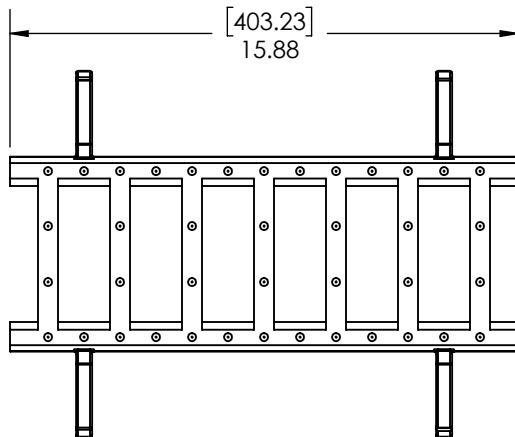

SYSTEM MFG	SYSTEM
TDS	POLYCAST 900

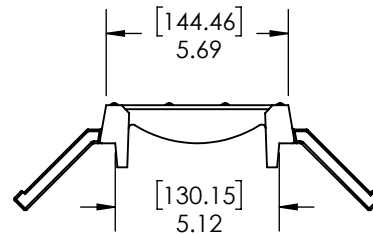
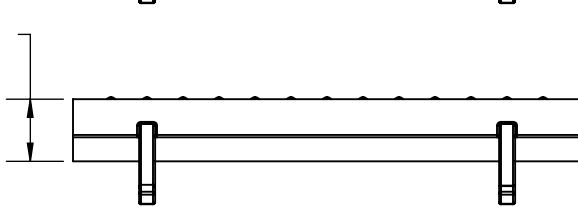

**MANUFACTURER**



DISCLAIMER - The customer and the customer's architects, engineers, consultants, and other professionals are completely responsible for the selection installation and maintenance of any product purchased from Trench Drain Systems and/or its manufacturers. TRENCH DRAIN SYSTEMS MAKES NO WARRANTY, EXPRESS OR IMPLIED, AS TO THE SUITABILITY, DESIGN, MERCHANTABILITY, OR FITNESS OF THE PRODUCT FOR CUSTOMERS APPLICATION. The drawing and information provided remain the property and copyright of the manufacturer listed. The manufacturer reserves the right to modify specification without notice.

**ENGINEERING SPECIFICATION**

TDS-POLYCAST HEAVY DUTY DUCTILE IRON GRATE & FRAME DESIGNED TO SUPPORT DYNAMIC HIGH SPEED WHEEL LOADS IN EXCESS OF AASHTO H-20. THE GRATE IS ONE PIECE AND NON-REMOVABLE. THE GRATE IS MADE OF ASTM A536 GR 65-45-12 (DUCTILE IRON) AND WIEGHS APPROXIMATELY 15LBS [6.80KG]. THE GRATE IS ONLY AVAILABLE IN A 16" [406MM] LENGTH.