



610-638-1221
 sales@trenchdrain.com
 PO BOX 377 - FREMONT, OH 43420

PROJECT ID: _____
 CONTRACT NO: _____

LOCATION: _____

RELEASED: 3.26.24
 REVISION: -

DG0692	POLYCAST 600 SERIES DUCTILE IRON PATRIOT GRATE
--------	--



PART NO.	MATERIAL	WEIGHT	OPEN AREA	FLOW RATE
DG0692	DUCTILE IRON	15 LBS.	21%	92.23 GPM PER LINEAR FOOT WITH 1/2" OF HEAD

DIN APPLICATION LOAD CLASS C:

CURB SIDES, HIGHWAY SHOULDERS AND PARKING AREAS. DESIGNED FOR A DISTRIBUTED PRESSURE OF 56,200 LBS. (250kN)

MEETS THE FOLLOWING STANDARDS & SPECIFICATION:

-THE AMERICANS WITH DISABILITIES ACT OF 1990: 4.5.4.

SYSTEM MFG	SYSTEM	LOCKING DEVICE	LOAD CLASS
HUBBELL	POLYCAST 500 w/DG0700AA FRAME	DA0542BH	D
	POLYCAST 500 w/DG0700PE FRAME	DA0542BH	D
	POLYCAST 600	DA0642B	C
	POLYCAST 700 w/ DG0700AA FRAME	DA0642BH	D
	POLYCAST 700 w/ DG0700PE FRAME	DA0642BH	D
TDS	SS0600	SS0642B	C

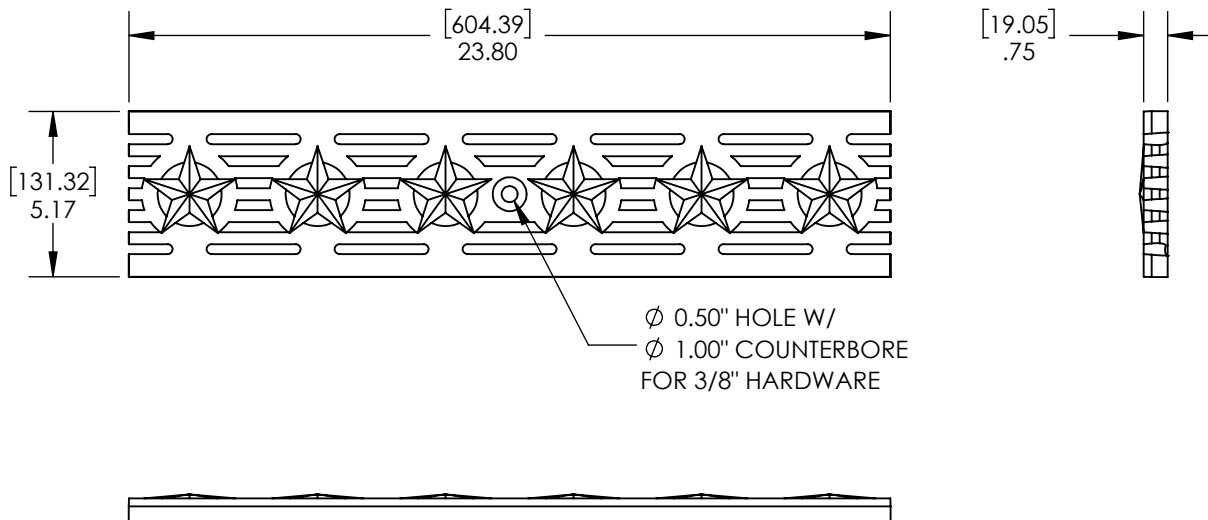

DISCLAIMER - The customer and the customer's architects, engineers, consultants, and other professionals are completely responsible for the selection installation and maintenance of any product purchased from Trench Drain Systems and/or its manufacturers. TRENCH DRAIN SYSTEMS MAKES NO WARRANTY, EXPRESS OR IMPLIED, AS TO THE SUITABILITY, DESIGN, MERCHANTABILITY, OR FITNESS OF THE PRODUCT FOR CUSTOMERS APPLICATION. The drawing and information provided remain the property and copyright of the manufacturer listed. The manufacturer reserves the right to modify specification without notice.