

BA-BARS-0520

GRATE BRONZE AGE BAR PATTERN



MATERIAL	MATERIAL SPEC	FINISH (SEE NOTE)	WEIGHT	OPEN AREA	FLOW RATE
DUCTILE IRON	ASTM A536-80 GR. 65-45-12	BLACK PRIMER	10.5 LBS	23%	44.4 GPM PER LINEAR FOOT WITH 1/2" OF HEAD



DIN APPLICATION LOAD CLASS E:

INDUSTRIAL AREAS, FORK TRUCKS, TRAFFIC PORTS AND DOCK SIDES. DESIGNED FOR A DISTRIBUTED PRESSURE OF 134,800 LBS. (600kN)

MEETS THE FOLLOWING STANDARDS & SPECIFICATIONS:

- THE AMERICANS WITH DISABILITIES ACT OF 1990: 4.5.4
- ASME A112.6.3 SECTION 7.12 HEEL RESISTANT STRAINERS AND GRATES.

FINISH NOTE: GRATES ARE SUPPLIED WITH A BLACK PRIMER TO TEMPORARILY PREVENT RUSTING. THIS COATING WILL SLOWLY WEAR OFF AND LEAVE A RICH DARK BROWN FINISH. RED RUST MAY AND/OR WILL APPEAR DURING THIS PROCESS.

SYSTEM MFG	SYSTEM	LOCKING DEVICE
ULMA	U100K U100KX D100 HYDROPLUS	LD100X-3
	U100K CATCH BASIN	LD100X-3CB
	M100K M100KX M100V HYDROPLUSmini	LD100MX-3
ABT	POLYDRAIN	810A 810AXL (WITH FRAME)
ACO	K100 KS100 H100K-6/H100KS-6 H100K-8/H100KS-8	N/A

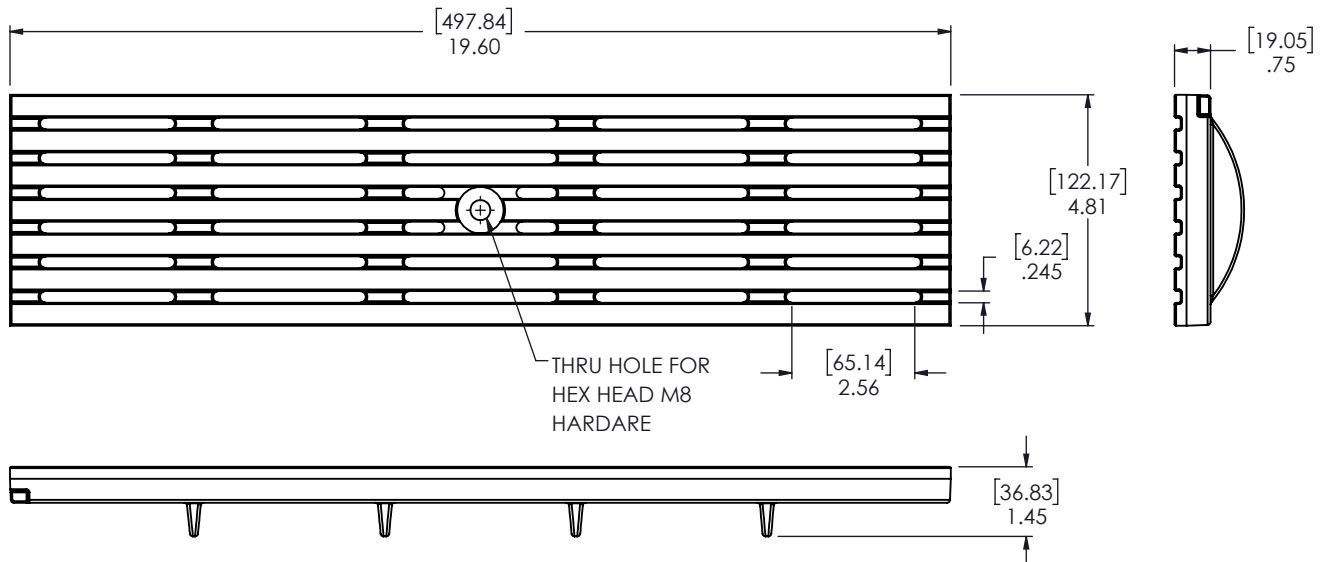

PATENT PENDING © 2021 TRENCH DRAIN SYSTEMS



DISCLAIMER - The customer and the customer's architects, engineers, consultants and other professionals are completely responsible for the selection, installation and maintenance of any product purchased from Trench Drain Systems and/or its manufacturers. TRENCH DRAIN SYSTEMS MAKES NO WARRANTY, EXPRESS OR IMPLIED, AS TO THE SUITABILITY, DESIGN, MERCHANTABILITY, OR FITNESS OF THE PRODUCT FOR CUSTOMERS APPLICATION. The drawing and information provided remain the property and copyright of the manufacturer listed. The manufacturer reserves the right to modify specification without notice.